

Mixed flow fans

KD 400 XL-450 M3



- High efficiency – low noise
- Speed-controllable
- Integral thermal contacts
- Can be installed in any position
- Maintenance-free and reliable

The KD fans have an external rotor motor with a mixed flow type impeller. The KD series is notable for its relatively high static pressure and high level of efficiency.

Brackets are supplied with the fans to make installation easier. The FK mounting clamp facilitates easy installation and removal, and prevents the transfer of vibration to the duct.

To protect the motor from overheating the KD fans have integral thermal contacts with leads for connection to a motor protection device. The casing is manufactured from powder-coated galvanised sheet steel.

KD		400 XL1	400 XL3	450 M1	450 M3
Voltage/Frequency	V/50 Hz	230	400	230	400
Phase	~	1	3	1	3
Power	W	855	792	857	778
Current	A	4,24	1,53	4,21	1,53
Maximum air flow	m ³ /s (m ³ /h)	1,62 (5839)	1,65 (5936)	1,60 (5774)	1,64 (5915)
R.p.m.	min ⁻¹	1298	1304	1308	1307
Max. temp. of transported air	°C	65	67	65	70
" when speed-controlled	°C	65	67	65	70
Sound pressure level at 3 m *	dB(A)	61	61	61	63
Weight	kg	32	29	31	29
Insulation class, motor		F	F	F	F
Enclosure class, motor		IP 54	IP 54	IP 54	IP 54
Capacitor	µF	16	-	16	-
Motor protection		S-ET 10	STDT 16	S-ET 10	STDT 16
Speed control, five-step	Transformer	RTRE 5	RTRD 2	RTRE 5	RTRD 2
Speed control, five-step high/low	Transformer	REU 5 + S-ET 10	RTRDU 2	REU 5 + S-ET 10	RTRDU 2
Speed control, stepless	Thyristor	-	-	-	-
Wiring diagram p. 11-17		6	8	6	8

* According to 20 m² Sabine

KD 400 XL

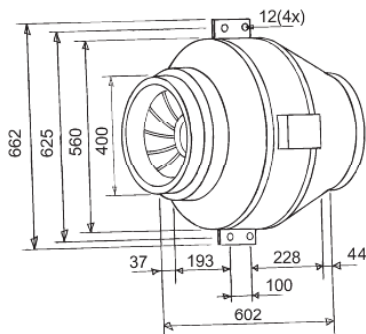

KD 450 M

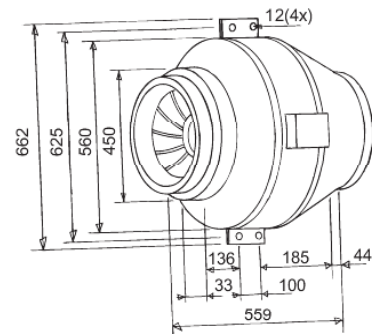

Mixed flow fans

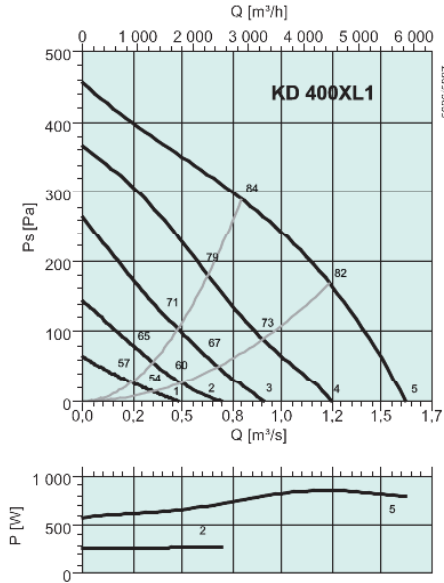

KD 400 XL1

		Mid-frequency band, Hz									
		Hz	Tot	63	125	250	500	1k	2k	4k	8k
L_{wA}	Inlet	dB(A)	84	55	79	78	78	71	68	66	58
L_{wA}	Outlet	dB(A)	85	55	79	80	79	75	71	69	61
L_{wA}	Surrounding	dB(A)	68	11	53	60	66	58	54	51	41
With LDC 400-900											
L_{wA}	Inlet	dB(A)	76	52	74	68	65	64	63	60	51
L_{wA}	Outlet	dB(A)	77	52	74	70	66	68	66	63	54

Measuring point: $q_v = 0,80 \text{ m}^3/\text{s}$, $P_s = 290 \text{ Pa}$

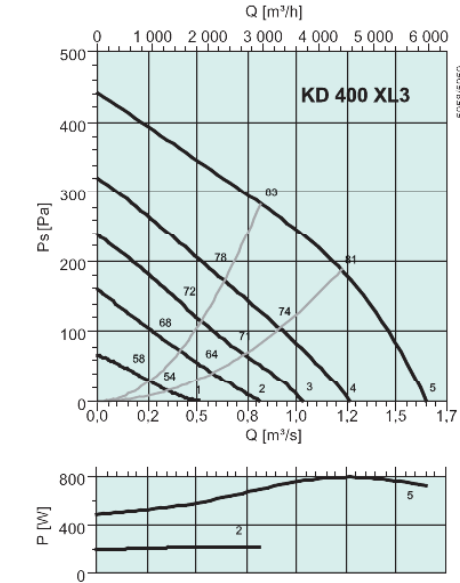

KD 400 XL3

		Mid-frequency band, Hz									
		Hz	Tot	63	125	250	500	1k	2k	4k	8k
L_{wA}	Inlet	dB(A)	83	53	78	77	77	71	68	66	58
L_{wA}	Outlet	dB(A)	85	55	78	79	79	75	72	70	60
L_{wA}	Surrounding	dB(A)	68	18	44	61	65	61	53	51	42
With LDC 400-900											
L_{wA}	Inlet	dB(A)	75	50	73	67	64	64	63	60	51
L_{wA}	Outlet	dB(A)	77	52	73	69	66	68	67	64	53

Measuring point: $q_v = 0,82 \text{ m}^3/\text{s}$, $P_s = 283 \text{ Pa}$

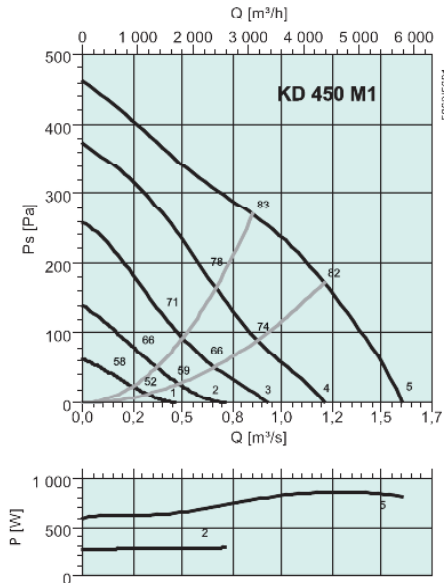

KD 450 M1

		Mid-frequency band, Hz									
		Hz	Tot	63	125	250	500	1k	2k	4k	8k
L_{wA}	Inlet	dB(A)	83	57	78	79	77	69	68	65	58
L_{wA}	Outlet	dB(A)	83	52	75	76	79	75	70	66	61
L_{wA}	Surrounding	dB(A)	68	25	47	67	61	56	55	50	43

Measuring point: $q_v = 1,12 \text{ m}^3/\text{s}$, $P_s = 234 \text{ Pa}$

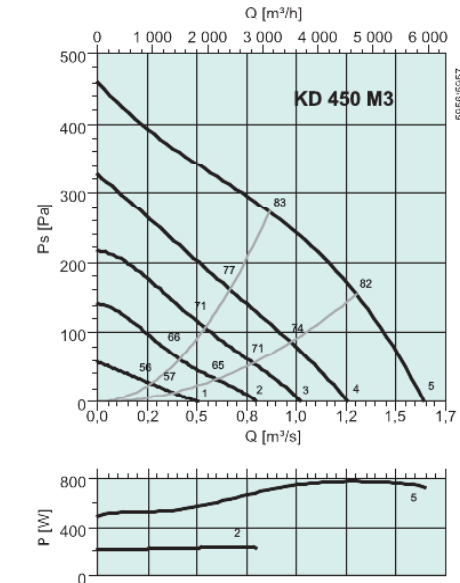

KD 450 M3

		Mid-frequency band, Hz									
		Hz	Tot	63	125	250	500	1k	2k	4k	8k
L_{wA}	Inlet	dB(A)	83	53	78	78	77	68	68	66	58
L_{wA}	Outlet	dB(A)	84	52	77	77	80	75	71	69	61
L_{wA}	Surrounding	dB(A)	70	15	45	68	66	59	53	50	42

Measuring point: $q_v = 0,87 \text{ m}^3/\text{s}$, $P_s = 273 \text{ Pa}$